

HOME, GARDEN & REMODELING SHOW

PRESENTED BY **CHAMPION**

Exhibitor's Manual

March 1-3, 2019

Kentucky Exposition Center
South Wing B & C

Produced by:



Presented By:



Sponsored by:



www.LouisvilleHomeShow.com

Table of Contents

| | |
|-----------------------|--|
| Page 3 | General Show Inquiries |
| | Show Contacts |
| | Show Services |
| | Location |
| | Shipping |
| Page 4..... | Show Office Hours |
| | Exhibitor Packets |
| Page 5 | Parking Passes |
| | Parking and Show Entrance |
| Page 6 | Move- In Procedures |
| | Set Up Times |
| | Move-In Schedule |
| Page 7 | Drive In Passes |
| Page 8 | Move-Out Schedule |
| | Exhibitor’s Lounge |
| Page 9 | Discount Tickets |
| | Will Call Tickets |
| | Deadlines |
| Page 10 | Important Things to Remember |
| | Linking Your Website |
| | Promotional Show Materials |
| | New Products and Services |
| Page 11..... | Directions |
| | Hotel Information |
| | Safety Tips |
| Page 12..... | Drive-In Pass Request Form |
| Page 13..... | Parking Pass Order Form |
| Page 14 | Ticket Order Form |
| Page 15 | How to Earn Free Tickets |
| Page 16 | Application to Receive Free Tickets |
| Page 17 | Things to Remember |
| Page 18,19 | Booth Layout and Guidelines |
| Page 20..... | Fire Marshall Requirments |
| Page 21, 22, 23 | Building Policies, Rules and Regulations |

General Show Information

Show Dates

& Hours

Friday, March 1st - 10:00 am - 9:00 pm

Saturday, March 2nd - 10:00 am – 9:00 pm

Sunday, March 3rd - 10:00 am – 5:00 pm

Contact Information/Show Services

Show Management

Building Industry Association of Greater Louisville

Ally Adams

Show Director

ally@bialouisville.com

502-429-0513

Emily Boog

Assistant Show Director

emily@bialouisville.com

502-429-6000 Ext:108

Decorator

Excel Decorators (*carpet/table/ chair rentals/ sign hanging*)

502-962-1119, Barb Arbuckle

www.exceldecorators.com

Electrical & Water

Kentucky Exposition Center

502-367-5321

www.kyexpo.org/kec/ExServices.aspx

(Register by February 1st for the advanced discount rate)

Phones & Internet

Kentucky Exposition Center

502-367-5275

<http://www.kyexpo.org/images/documents/KEC-IT-Form.pdf>

Location & Shipping

Kentucky Exposition Center -- South Wing B & C

937 Phillips Lane, Louisville, KY 40209

502-367-5000

When shipping, please include your company name, South Wing B and booth number

Show Office/Service Desks Hours

Show Management/Exhibitor Information, Excel Decorators Services & the Kentucky Exposition Center will be in South Wing B Lobby during Move-In.

- Monday, February 25th 2:00 pm – 5:00 pm
- Tuesday, February 26th 9:00 am – 5:00 pm
- Wednesday, February 27th 9:00 am – 6:00 pm
- Thursday, February 28th 8:30 am - 6:00 pm
- Friday, March 1st 9:30 am – 9:00 pm
- Saturday, March 2nd 9:30 am – 9:00 pm
- Sunday, March 3rd 9:30 am – 5:00pm

The exhibitor information desk will remain in the South Wing B lobby throughout the event.

Exhibitor Passes

10' x 10' Booth 5 passes per day
(1 additional pass per each additional 10 x 10 space)

20' x 20' Bulk Space 7 passes per day

20' x 30' Bulk Space 8 passes per day

OVER 700 Sq. Ft. up to 10 passes per day
(Show Management must approve any additional passes)

Exhibitor Packets- Pickup Dates and Locations

Credentials & Parking Passes will not be mailed – they must be picked up and signed out

- **Wednesday, February 6th - Friday, February 22rd**
****Earn 10 FREE show tickets if you pick up your tickets during this time****
Building Industry Association Office,
1000 N. Hurstbourne Pkwy., Louisville, KY 40223
Office Hours are Monday-Friday from 8:30 am to 4:30 pm

- **Monday, February 25th – Thursday, February 28th**
Kentucky Exposition Center Show Office - South Wing B Lobby
937 Phillips Lane, Louisville, KY 40209

PARKING PASSES- \$25 each while supplies last

There is a limited allotment of parking passes available. The passes will be valid for March 1st – March 3rd. To order, please see the parking pass order form enclosed on page 12. No parking passes will be sold after February 22nd – or when they run out.

**All parking passes must be paid in full before you receive passes.*

PARKING AND SHOW ENTRANCE

USE THE MAIN ENTRANCE - or the red doors next to overhead doors E-19 and E-13 (E-13 is also the Smoking area for exhibitors)

- **All exhibitors are to park in Lot D (the horse barn area) or Lot E (behind the stadium).**
 - Exhibitors are encouraged to use the walk-over located behind the North Wing. That breezeway takes you right to the South Wing A lobby where you will then walk to the South Wing B lobby area. Exhibitors may enter the Show through the main doors in the South Wing B lobby at the “Exhibitor Entrance”.
 - We understand this is a walk but we would like to have as many spots for consumers in the front of the buildings as possible. There is also limited parking across from door E-19 – your vehicle must be in the parking lot.
- **Any Vehicles displaying a company logo that are parked in Lot A or Lot N (the lots in front of Southwing B or C) are subject to be towed at the violators expense. This area is designated for our event attendees only.**
- **All large trucks or vehicles with trailers should park in Lot D (by the horse barns.)**

Same Day Re-Entry

- For same day re-entry, exhibitors can simply have their hand stamped at the lobby entrance or the Exhibitor Entrances at E-19 or at E-13 on their way out.
- Hands will be stamped on the way out, not on the way in!
- The stamps will be different each day.

No Alcoholic Beverages to be brought in:

303 Kentucky Administrative Regulation 1:030, Section 1 states:
No person shall carry or transport into the premises any beer or other alcoholic beverages.

Set Up and Move-In Particulars

Set Up Week- Monday, February 25th - Thursday, February 28th

****Please carefully review the details of move in. Specific move-in days are based on your booth size and location.****

NO VEHICLES ARE ALLOWED IN THE BUILDING ON THURSDAY, February 28th

- Designated move-in times will be assigned to exhibitors by Show Management.
- Limited vehicles will be permitted inside the Exposition Halls and will be allowed in only during designated move-in times (see additional pages for details).

Aisle Booths- Designated Set Up Times (Single or Multiple)

- Wednesday, February 27th begins at 11:00 a.m.
- This includes all 10'x10' booths even if there are multiple 10'x10's
- You must obtain written permission from the Show Management for any other Move-In time.

Bulk Booth- Designated Set Up Times

- South Wing B Exhibitors
Monday, February 25th - From 2:00 p.m.– 9:00 p.m.
Tuesday, February 26th - From 8:00 a.m.- 9:00 p.m.
- South Wing C Exhibitors
Monday, February 25th- From 5:00 p.m.- 9:00 p.m.
Tuesday, February 26th – From 8:00 a.m.– 9:00 p.m.
- All Exhibitors
Wednesday, February 27th
Limited vehicles will be allowed to access the show floor
From 8:00 a.m. – 9:00 p.m.
- **NO VEHICLES ALLOWED**
Thursday, February 28th from 8:00 a.m. – 9:00 p.m.

Vehicles- Set Up and Move In

ALL booths that that require bringing a vehicle on the show floor during set up are required to have a Drive In Pass. Passes must be requested in advance and must be displayed in the front windshield of the vehicle during the time of entry. Drive In Passes are limited to 2 per company and we will not replace any lost or stolen passes. Companies should NEVER have more than 2 vehicles in the building at one time.

- Bulk Island Booths can bring their vehicles in from Monday, February 25th – Tuesday, February 26th depending on the location of the booth and designated move-in times.
- Aisle booths will only be allowed to bring a vehicle on the show floor Wednesday, February 27th. A Drive In Pass is required and must be displayed in the front windshield of the vehicle upon entry. No aisle or 10'x10' booths will be allowed to bring vehicles prior to Wednesday, February, 27th.
- ****No Vehicles will be allowed in the building on Thursday, February 28th****

Bulk Booths #100 – #1299 - South Wing B

Use doors E-13 thru E19

- All vehicles entering the building require a Drive-In pass visibly displayed in front windshield**
- Monday, February 25th (2:00 p.m. – 9:00 p.m.)
- Tuesday, February 26th (8:00 a.m. – 9:00 p.m.)
- Limited vehicles will be allowed in Wednesday, February 27th.

Bulk Booths #1301 and #2300 - South Wing C

Use door E-16 thru E19

- All vehicles entering the building require a Drive-In pass visibly displayed in front windshield**
- Monday, February 25th (5:00 p.m. – 9:00 p.m.)
- Tuesday, February 26th (10:00 a.m. – 9:00 p.m.)
- Limited vehicles will be allowed in Wednesday, February 27th.

MOVE IN – 10 x 10 BOOTHS

- Wednesday, February 27th & Thursday, February 28th
(must have a drive in pass to bring a vehicle in)
- Includes all 10' x 10' Booths (single or multiple)
- **NO DRIVE IN ON THURSDAY, February 28th.**

10'x10' MOVE IN RULES

- Move- In begins Wednesday, February 27th at 11:00 a.m.
- All items must be carried or carted in unless you obtain permission to drive-in.
- Vehicle passes are required and you will not be allowed to drive in the hall without one. NO LARGE TRUCKS AND NO TRAILERS ALLOWED. Please fax your request for a drive-in pass, see page 12.
- Drive-in Passes will be distributed with the credentials on a limited basis. A drive-in pass allows you to get close to your booth – it is for unloading only (not set-up).
- To enter the building prior to this time you must have written permission from Show Management.
- Show management reserves the right to hold vehicles from pulling in if there is a traffic issue in the hall. This is what makes it important to unload your vehicle and move it out – since in many cases vehicles will not be allowed in until another pulls out.

NO VEHICLES ALLOWED THURSDAY, February 28th

DRIVE-IN PASSES

- **NO VEHICLES WILL BE ALLOWED ON THE SHOW FLOOR ON THURSDAY, FEBRUARY 28th FOR ANY REASON EVEN WITH A DRIVE-IN PASS!**
- All Bulk spaces will have move-in times and two (2) DRIVE-IN passes provided.
- Any 10' x 10' that REQUIRES a drive-in pass must submit a request and receive approval from Show Management. NO LARGE TRUCKS AND NO TRAILERS ALLOWED. (Please refer to Request Form for Drive-In Pass included in this manual.)
- Please enter through Door E-19 along the South wall of South Wing C.
- Vehicles that enter the show floor must unload and exit the facility. No vehicles shall park on the Show floor during booth set up.
- You will not be allowed to work off of your vehicle.
- All vehicles are required to have a pass in the windshield in order to enter the building and must remain visible in the windshield of the car/truck while in the building
- Show Management will not reissue any lost or stolen Drive-In passes

Exhibitor's Lounge

- **Room C-101**
- **LOCATED IN THE HALLWAY BETWEEN SOUTH WING B & C LOBBIES**
- The Exhibitor's Lounge will offer exhibitors a place to sit and enjoy a break away from the public.
- This area is to allow exhibitors a break from the Show floor (It is not guaranteed to provide food or beverage.)

| | | |
|--|-----------------------------------|------------------|
| Exhibitor's Lounge Days and Hours | Friday, March 1 st : | 12 Noon – 7 p.m. |
| | Saturday, March 2 nd : | 12 Noon – 7 p.m. |
| | Sunday, March 3 rd : | 12 Noon – 3 p.m. |

Move-Out Schedule

Do Not Breakdown Early or Move-Out Before 5:01 p.m. on Sunday, March 3rd

- Any exhibiting companies that breakdown any part of their booth display down prior to Sunday, March 3rd at 5:01 p.m. are subject to fines and penalties.
- Fines will be enforced and you will forfeit your early space reservation for the following year.

Move-Out- 10' x 10' and Aisle Booth Spaces

Sunday, March 3rd- From 5:01 p.m. to 10:00 p.m.

- Move-out begins for all single and multiple 10 x 10 booth spaces on Sunday, March 3rd at 5:01 p.m, **NO SOONER, NO LATER.**
- Booths must be broken down and removed by 10:00 p.m. on Sunday, March 3rd
- Please note that due to the size of the Show and time management, all 10 x 10 single and multiple booth spaces are required to move-out prior to 10 p.m. the closing night of the show.
- All trash (including tape) must be removed completely or subject to fines

Move-Out – Bulk Spaces

Sunday, March 3rd & Monday, March 4th

- Bulk booth spaces can begin breakdown on Sunday, March 3rd at 5:01 p.m.
- Move out on Sunday, March 3rd will be from 5:01 p.m. until 10:00 p.m.
- Monday, March 5th Move Out time is from 8:00 a.m. to 5:00 p.m.
- ALL exhibits must be moved out no later than 5:00 p.m. Monday, March 4th.
- There will NOT BE any release slips issued – please take ALL valuable items out at the close of the Show.
- Any booths that are not completely removed by 5:00 p.m. are subject to fines issued by Show Management
- All trash (including tape) must be removed completely or subject to fines

Will-Call Tickets

- Will-Call tickets or passes must be left at the Main Gate “Exhibitor Entrance” at the South Wing B Entrance placed in a properly marked envelope.
- Clearly mark your name and/or the company name to the envelope. Also include the name of the recipient and the number of tickets enclosed.
- If you have several recipients picking up from your allotment, please indicate the number of tickets per person.
- Tickets or passes not claimed will be carried over until the next day.
- Tickets must be marked clearly and placed in an envelope.

Deadlines

- **December 28th** - all booth balances due!
- **February 1st** - all advanced electrical and water orders** must be submitted to Kentucky Exposition Center. Call 502-367-5321 or visit www.kyexpo.org
- **February 15th** - all advanced Excel Decorators Services** (carpet, tables, chairs, etc.) orders must be submitted. Call 502-962-1119 or visit www.exceldecorators.com
- **Services order after the posted dates above are subject to increased pricing!**

Enhancing Your Exhibiting Experience

Website Links and Product Category Listings

Exhibitors have the ability to have their web site linked with the online listing(s) as seen on the web pages at www.louisvillehomeshow.com. The cost for the link is ONLY \$20.00.

All Exhibitors are allowed 2 complimentary product category listings in the official Home, Garden and Remodeling Show program. Exhibitors will also be included on our www.louisvillehomeshow.com website and listed under searchable categories. Any company that would like to be listed under more than the 2 complimentary categories can purchase additional listings for \$5.00 each.

Exhibitors interested in this listing service should contact Ally Adams (ally@bialouisville.com) or Emily Boog (emily@bialouisville.com) or call 502-429-6000.

Promotional HGRS Material (Available by end of January)

Promotional materials for the **Home, Garden & Remodeling Show** will be made available to exhibiting companies at no cost. This is a great way to promote your involvement in the Show and drive traffic to your booth. If you have a store front, showroom or counter space, we offer promotional posters and counter top signage. The signs and posters will offer a space to display your company name and booth number. You can pick them up in our BIA office.

Provide us with details about your new and exciting products or services!

If you are promoting new or unusual products or services, please send a written description for potential media purposes. We want to hear what sets you apart from your competition and any highlights related to your products and services. If Show Management deems appropriate, items will be promoted through Home Show public relations and marketing efforts.

Send submissions to Ally Adams at ally@bialouisville.com, Emily Boog at emily@bialouisville.com. The sooner the better!

Include the HGRS Logo in your Marketing and Advertising

Request the official Home, Garden and Remodeling Show logo by reaching out to Ally Adams at ally@bialouisville.com, Emily Boog at emily@bialouisville.com. Exhibiting companies that use the logo within their marketing and advertising material will receive 10 free tickets to the 2019 HGRS.

SHOW NO'S!

- **NO EARLY BREAKDOWN OR MOVE-OUT BEFORE 5:01 P.M. ON SUNDAY, MARCH 3RD!**
- No flyers or handouts outside your booth area. Any literature placed outside an exhibitor's booth area (on food court tables or on top of garbage cans) will be discarded and will result in the exhibitor receiving an invoice for additional booth space. Amount to be determined by Show Management.
- Exhibitors are not permitted to promote or sell anything outside of the booth space they have purchased. Attendees must approach the exhibiting booths. Exhibitor must not approach attendees anywhere outside purchased/designated booth space.
- If you happen to have anyone approach you marketing a product or service, please collect all the information you can and immediately contact show management. We do not allow solicitation on our show floor except inside the purchased booth space of an exhibitor.
- Each exhibitor must pick up all trash (including floor tape) and take it with them at the end of the Show. The Kentucky Expo Center will now charge for pick-up or removal of left over materials. ***THIS INCLUDES DOUBLE-SIDED TAPE IF YOU PUT CARPET DOWN.***

Directions & Where to Park

Directions to the Kentucky Exposition Center – USE GATE 2 & BEAT THE TRAFFIC

The Kentucky Exposition Center is located at the junction of I-65 and I-264 in Louisville. Signs reading "KY Expo Center" on both interstates lead to the main gate. Visitors may want to beat the traffic by entering Gates 2 & 4 on Crittenden Drive or Gate 6 on Preston Highway. Visitors traveling from out of the state will find getting to the Kentucky Exposition Center easy as we are located just minutes from the Louisville International Airport. For more specific directions call the KY Expo Center at 502-367-5000 or visit <http://www.kyfairexpo.org>.

Hotel Information

For a list of hotels near and around the show, please visit <http://www.kentuckyexpositionhotels.com/>

Security Tips

Nothing will ruin a successful exposition experience more than the loss or theft of expensive equipment or products. Here are some basic steps you can take to prevent theft.

1. Show management, the building operator, the general contractor, and the security company provides a measure of protection, such as providing perimeter security. But only you and your staff are responsible for your valuables.
2. Don't identify the product or manufacturer on the outside of freight cartons. Mark cartons numerically to indicate the total being shipped (1 of 6). Include your company's name and booth number in your cartons. Furnish your freight forwarder with an accurate and complete bill of lading.
3. Escort your merchandise and/or goods to your booth if at all possible. The greatest risk of theft occurs during set up and tear down. Be especially alert during these times.
4. Treat valuable goods such as prototypes as irreplaceable. If they are one-of-a-kind, hire your own security. Under no circumstances should such goods ever be left unattended. Televisions, computers and other electronic devices are particularly vulnerable to theft.
5. At the close of business each day, cover all display tables. This establishes a barrier to curiosity-seekers and other would-be thieves from selecting items to steal at a later time. Store excess supplies and merchandise with the material handling contractor or in a facility outside the hall. Never store your excess merchandise or supplies under tables or displays. That's the first place a thief will look!
6. During tear down, stay with your exhibit until your empty cartons are delivered and your goods are packed, sealed and properly labeled.
7. Obtain proper insurance coverage for your goods, including transit to and from the show site.

Show Management will not allow any exhibitors or their workers in the Exposition Hall after close of the Show each day. During Move-in all exhibitors and workers will be made to leave the building at 10 p.m. each night. Exhibitors and workers will not be allowed into the Exposition Hall until 1 hour prior to opening on Show days at the time of open on move-in/move-out days.

To help us secure the building to the best of our ability we ask that you cooperate with these rules regarding people in the building. THANK YOU.



HOME, GARDEN & REMODELING SHOW

MARCH 1-3, 2019

PRESENTED BY **CHAMPION**

Drive-In Pass Request

NO VEHICLES WILL BE ALLOWED ON THE SHOW FLOOR ON THURSDAY, FEBRUARY 28TH

Company: _____

Contact Name: _____

Booth Number: _____ Make/Type of Vehicle: _____

Cell Phone: _____

E-mail: _____

- Drive-In passes allow exhibitors to bring in a vehicle for loading and unloading purposes during move-in and move-out.
- Vehicles entering the show floor must unload items at designated booth location and exit the building immediately following.
- Drive-In passes will be included in your exhibitor's packet.
- Passes must be prominently displayed in the front window of the vehicle during the time of entry.
- Drive-In passes are required at all times when inside the facility, no exceptions.
- Any vehicle not displaying the Drive-In pass or that is parked and unattended during move-in or move-out is subject to fines and/or towing.
- Not all requests are guaranteed to be honored. **NO LARGE TRUCKS and NO TRAILERS.**
- Drive-In passes will not be reissued for any reason including lost or stolen passes.
- Drive-In passes and vehicles ARE NOT valid on Thursday, February 28th.

Email your request to ally@bialouisville.com or emily@bialouisville.com

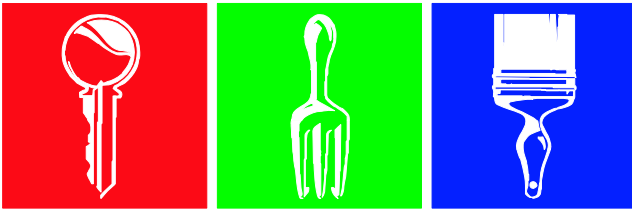

HOME, GARDEN & REMODELING SHOW

PRESENTED BY **CHAMPION**

March 1-3, 2019

KEC -South Wing B & C

PARKING PASS ORDER FORM

Parking Passes are \$25 each and valid March 1-3, 2019

Company Name: _____

Contact: _____

Phone: _____ E-mail: _____

_____ Number of Parking Passes (\$25 each) you would like to order

_____ Total Amount Due

- I understand these passes **MUST BE PAID FOR IN FULL** in order to pick them up with my exhibitor move-in packet. I also understand that passes must be purchased before Friday, February 22, 2019 and supplies are limited.
- If you ordered parking passes with your booth registration, you are not required to fill out this form.
- This form is for ordering additional parking passes beyond what you requested during registration.

_____ Check Enclosed _____ Please charge my Visa/MC

_____ Please bill my BIA account (BIA Members ONLY)

Visa/MC Card ONLY: # _____

Expiration Date: _____ Security Code: _____

Name on Card: _____

| | |
|-------------------------------|---------------|
| _____ Authorized Signature | _____ Date |
|-------------------------------|---------------|

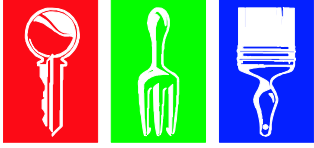

HOME, GARDEN & REMODELING SHOW

PRESENTED BY **CHAMPION**

March 1-3, 2019

KEC –South Wing B & C

TICKET ORDER FORM

Sponsored by: **LGE**
a PPL company

Ticket Order Form – \$5 each (50%discount)

ORDER NOW FOR YOUR CUSTOMERS, FRIENDS & FAMILY

Discount tickets that are to be mailed must be ordered by February 20, 2018. Discount tickets will not be sold after February 28th, 2019.

Purchase discount tickets for \$5 per ticket. Tickets will be available for pick-up at the BIA Office at 1000 N. Hurstbourne Parkway until Feb. 22nd. Tickets mailed will be subject to a postage and handling fee.

Company Name: _____ Booth #: _____

Contact Name: _____

Phone: _____ E-mail: _____

Address: _____

____ Include my tickets in my Exhibitor Packet OR ____ Mail my tickets (\$1 service fee applies)

Number of Tickets (\$5 each) _____

Total Amount Due \$ _____

____ Please bill my BIA account ____ Check Enclosed ____ Please charge my Visa/MC

Visa/MC Card # _____

Expiration Date: _____ Name on Card: _____

I understand that my company will be charged for tickets as stated above. I also understand that these tickets are non-refundable. No refunds for unused tickets.

Signature

Date

EMAIL to ally@bialouisville.com or emily@bialouisville.com OR FAX to 502-429-6036

THINGS TO REMEMBER

- **ADVERTISE NOW!** The **Home, Garden & Remodeling Show** will publish a *Program Guide* that will be distributed at the door of the event in addition to a target specified mailing list. For more information on pricing, ad specs, and distribution of this quality printed publication, please contact Carrie Lyons (Carrie@bialouisville.com) or Lindsey Marquardt (Lindsey@bialouisville.com) or call 502-429-6000.
- **AUTOMOBILES, TENTS, BALLOONS & SAND!** Automobiles, tents, balloons and sand are prohibited. If any of these items are to be used in an exhibit the exhibitor must contact Show Management for specific rules governing said items with written permission.
- **ELECTRIC & TABLE ORDERS!** Please remember February 1st is the deadline to order electric, water and internet through the KEC. February 15th is the deadline to place orders for rental carpet, tables and chairs through Excel Decorators. All orders placed after these dates are not guaranteed and subject to higher prices.
- **INTERNET IN THE EXHIBIT HALL!** Please contact Convention Communications Provisioners at 800-453-5419 regarding internet connections during the show if this is needed.
- **LOAD IN and LOAD OUT!** **DO NOT USE THE FRONT DOORS OR THE LOBBY TO BRING IN OR TAKE OUT ANY BOOTH MATERIAL.** ALL booth materials should be brought in and taken out through the dock areas and overhead doors. Show Management has the right to assess a \$1000 fine for each infraction. This will be strictly enforced as the KEC (event venue) has emphasized a much tighter watch and distribution of fines to violators.
- **DO NOT MOVE OUT EARLY!** You will give up your space if you breakdown or move out early. Staff will be walking the show floor to take pictures and write down booth numbers and company names. Keep in mind, even with very few people on the Show floor in the last 30 minutes, they paid to get in and if you are not there then they ask for their money back and it reflects poorly on our event.
- **NO FOOD OR DRINK!** No food or drink is to be distributed to show attendees by exhibitors at the Kentucky Exposition Center.
- **REVIEW, REVIEW and REVIEW AGAIN!** Please review your booth regulations for set-up as stated on your agreement. 10'x 10' booth spaces (including multiples) will be limited on move-in and will have a move out deadline of March 3rd at 10:00 p.m. Please make arrangements to pre-build portions of your display prior to move-in and assemble during your allotted time and be prepared to tear down and move your booth on Sunday evening.

Contact us for an electronic version of the HGRS Logo:

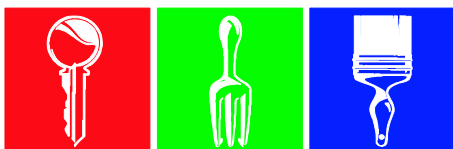

**HOME, GARDEN &
REMODELING SHOW**

PRESENTED BY **CHAMPION**

Include the Home
Show logo on all your
pre-show promotional
materials!

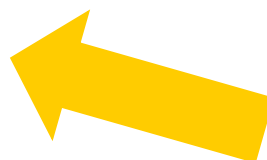

Exhibits

It is CRITICAL that your exhibit be set-up according to the Rules and Regulations as stated in your contract. This is especially true of all 10' x 10' booths. **** To allow for your display to comfortably fit inside the allotted 10 x 10 space please build specs no longer than 9'6". Pipe and drape will add a few inches inside each booth perimeter. ****

YOU CANNOT BUILD A 10' LONG and 8' HIGH WALL NEXT TO YOUR NEIGHBOR!!

The following information is a guideline to help you understand the Rules and Regulations of your particular booth space. If your space is not covered by the information provided feel free to call our Office at 502-429-6000 or e-mail ally@bialouisville.com or emily@bialouisville.com for more information about your booth space set up.

Linear Booth

Linear Booths have only one side exposed to an aisle and are generally arranged in a series along a straight line. They are also called "in-line" booths.

Dimensions

For purposes of consistency and ease of layout and/or reconfiguration, floor plan design in increments of ten feet (10') has become the de facto standard in the United States. Therefore, unless constricted by space or other limitations, Linear Booths are most commonly ten feet (10') wide and ten feet (10') deep, i.e. 10'x10'. A maximum backwall height limitation of eight feet (8') is generally specified.

Use of Space

Regardless of the number of Linear Booths utilized, (e.g. 10'x20', 10'x30, 10'x40', etc.) display materials should be arranged in such a manner so as not to obstruct sight lines of neighboring exhibitors. The maximum height of eight feet (8') is allowed only in the rear half of the booth space, with a four-foot (4') height restriction imposed on all materials in the remaining space forward to the aisle. (Note: When three or more Linear Booths are used in combination as a single exhibit space, the four foot (4') height limitation is applied only to that portion of exhibit space which is within ten feet (10') of an adjoining booth.)

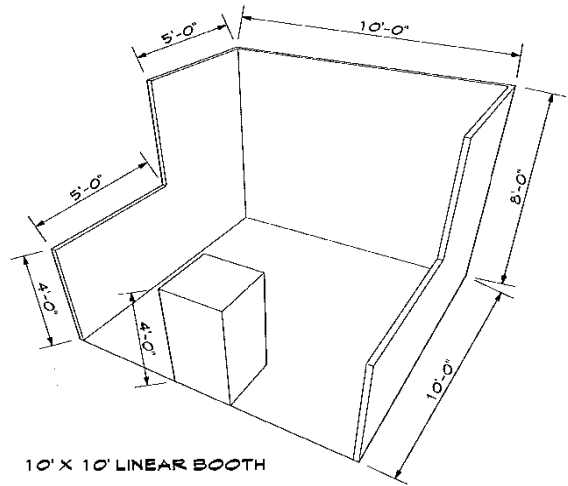

10' X 10' LINEAR BOOTH

Corner Booth

A Corner Booth is a Linear Booth exposed to aisles on two sides. All other guidelines for Linear Booths apply.

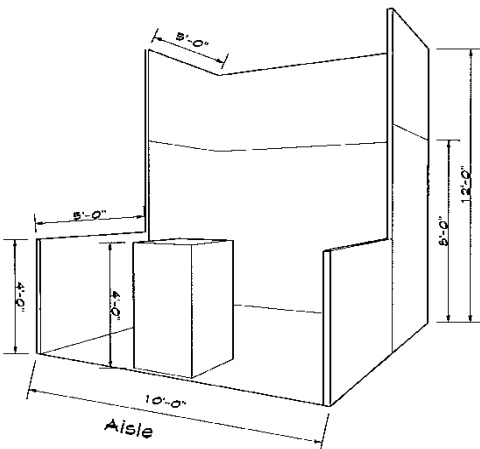
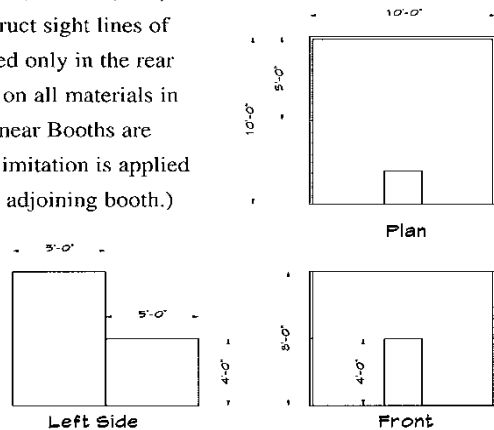

Perimeter Booth

A Perimeter Booth is simply a Linear Booth that backs to a wall of the exhibit facility rather than to another exhibit.

Dimensions and Use of Space

All guidelines for Linear Booths apply to Perimeter Booths except that the typical maximum backwall height is twelve feet (12').

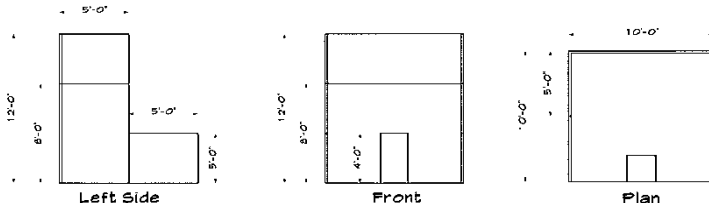

End-cap Booth

An End-cap Booth is exposed to aisles on three sides and composed of two booths.

Dimensions

End-cap Booths are generally ten feet (10') deep by twenty feet (20') wide. The maximum backwall height of eight feet (8') is allowed only in the rear half of the booth space and within five feet (5') of the two side aisles with a four foot (4') height restriction imposed on all materials in the remaining space forward to the aisle.

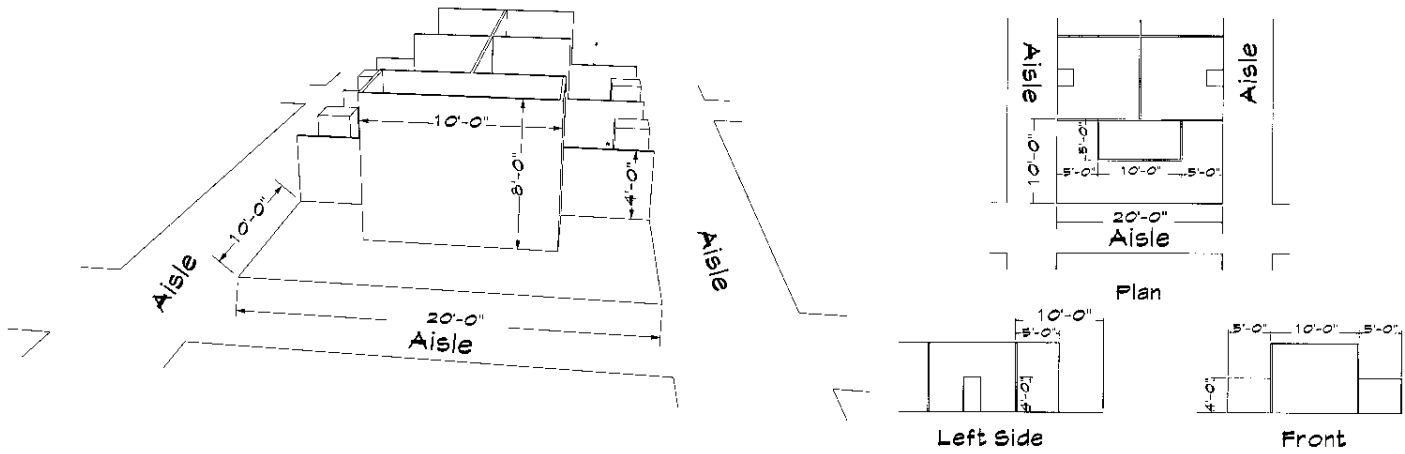

Peninsula Booth

A Peninsula Booth is exposed to aisles on three (3) sides and composed of a minimum of four booths. There are two types of Peninsula Booths: (a) one which backs up to Linear Booths, and (b) one which backs to another Peninsula Booth and is referred to as a "Split Island Booth."

Dimensions

A Peninsula Booth is usually 20' x 20' or larger. When a Peninsula Booth backs up to two Linear Booths, the backwall is restricted to four feet (4') high within five feet (5') of each aisle, permitting adequate line of sight for the adjoining Linear Booths. Sixteen feet (16') is a typical maximum height allowance, including signage for the center portion of the backwall.

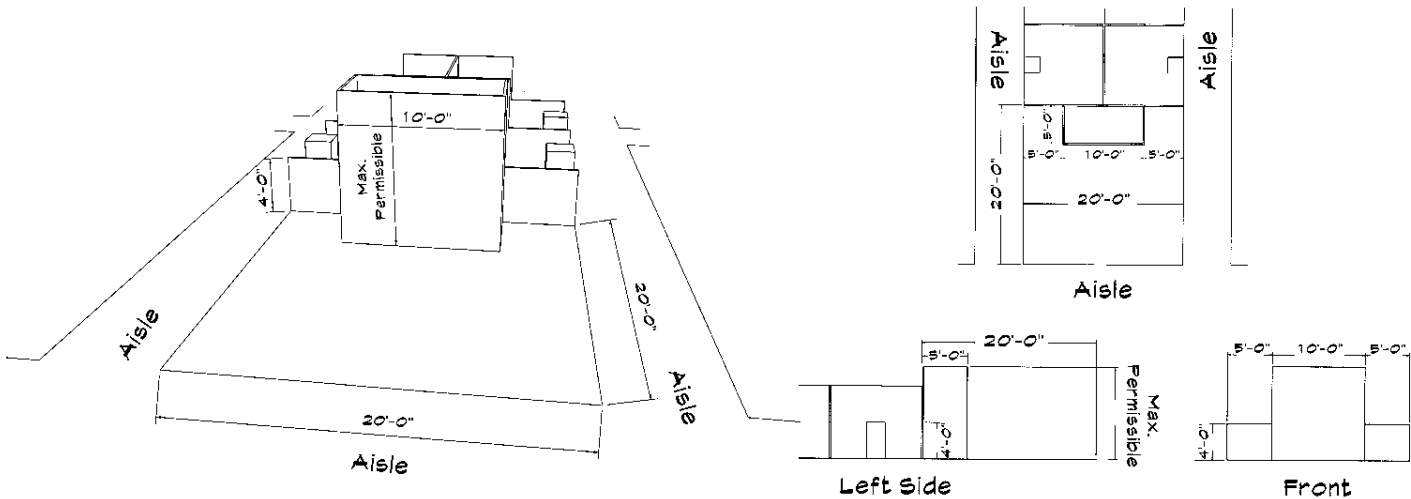

KENTUCKY STATE FIRE MARSHAL REQUIREMENTS – EXHIBITORS

The following are the State Fire Marshal's minimum fire safety requirements and shall be applied at all shows-trade, commercial or otherwise, and shall apply whether the exhibit space is open or closed to the public.

1. The display and operation of any cooking or heat producing appliances, pyrotechnics, use or storage of flammable liquids, compressed gases or any other process deemed hazardous by the State Fire Marshal must have advance approval by the KSFM Representative before it is brought to Kentucky Exposition Center.
2. Any motor vehicles, gasoline powered equipment, tools, etc., on display shall have their batteries disconnected. All fuel tanks that are not equipped with locking gas caps shall have the gas caps sealed with tape. All such fuel tanks shall be less than one-fourth full. Absolutely no storage of any fuel in any building.
3. No parking of any vehicles, unless approved, is allowed in the building or loading docks. Cars and trucks shall be removed immediately after loading or unloading.
4. Decorations and displays shall not block or impede access to fire protection equipment (smoke detectors, sprinklers, fire extinguishers, exit markings, exit doors or emergency lighting equipment.).
5. All decorations shall be fire retardant. The decoration companies/exhibitors shall be prepared to provide certificates of flame spread on all decoration items. Items that are not properly fire retardant shall be removed.
6. All exhibits, signage and displays must be "Open Top" and not interfere with the facility fire detection and suppression system.
7. "Closed Top" displays include canopies, horizontal signs, displays with roofs and multilevel displays.
 - Closed top displays must have prior written approval from the KSFM Representative
 - Approval requests for multilevel displays must be submitted 90 days in advance of show and include stamped engineer drawings of the structural components.
 - Enclosed displays must have a working smoke detector, which is audible outside the enclosure.
8. During occupancy hours, aisles and exit doors shall be maintained free of all obstructions and unlocked for immediate use in the event of an emergency.
9. Signs designating exits and the direction of travel to exits approved by the KSFM Representative shall be provided by the Lessee and in place prior to the show's opening.
10. Additional fire extinguishers may be required at the discretion of the KSFM Representative.
11. All electrical devices and installations shall be in accordance with the applicable provisions of the National Electrical Code. All electrical devices must be listed by an approved listing agency, (Underwriters Laboratories, Factory Mutual or Underwriters Laboratories Canada). All electrical extension cords used shall be of the heavy-duty type (at least 14-gauge wire). Lightweight cords of the lamp cord variety are prohibited: any cords and or devices that present a hazard will be subject to confiscation.
12. All Lessees, exhibitors and show personnel shall adhere to all other fire safety laws, regulations and codes that have been duly adopted
13. Kentucky Exposition Center shall require security where occupants are allowed to reside overnight inside of any state owned structure on the grounds. Security personnel shall be familiar with emergency response in the event of fire or other emergency, and perform regular surveillance of the areas where lodging occurs.
14. Lessee shall provide a list showing the number and location of persons boarding/dwelling overnight within the general vicinity of their exhibits.
15. It shall be the responsibility of the Lessee/show manager to see that the above regulations are followed.
16. Lessee will be responsible for making key personnel, including security, aware of and familiar with the facility's emergency procedures, which would include but not be limited to fire, bomb threats, inclement weather, etc.

For any additional information, please contact the Kentucky Exposition Center's Director of Operations at (502)367-5000 eventcoordination@ksfb.ky.gov - Revised 11/10/15

Policies - Building Rules and Regulations

The following regulations will be enforced during KEC events. It is your responsibility to inform your exhibitors, attendees and service contractors of these regulations. It is requested that this information be included in show brochures, meetings and/or exhibitor manuals. Any labor or material costs incurred by KEC by violation or ignorance of these regulations will be billed to the show management or the appropriate party.

- All exhibitors are subject to the Fire Marshal Regulations of the Commonwealth of Kentucky.
- The hanging of any type of signage, displays, etc., must be hung from structural steel ONLY. Hanging is strictly prohibited from sprinkler lines, water, gas or air lines, HVAC ductwork, electrical BUSS ducts or any other line. Items found hanging on these prohibited structures will be removed at owner's expense.
- No holes may be drilled, cored or punched in the building without prior written approval from facility management.
- No lighter - than - air (helium, etc.) balloons are permitted in any building. It is a violation of the City of Louisville ordinance to release lighter-than-air balloons into the atmosphere.
- No adhesive-backed (stick-on) decals, advertisements or similar items may be distributed or used at the facility.
- Decorations, signs, banner, etc., may not be taped, nailed, stapled or otherwise fastened to ceilings, walls, doors, painted surfaces or columns without prior written approval by facility management.
- All carpet tape applied by exhibitors, show management or their contract representatives will be removed by same immediately following the event.
- All freight and exhibit materials must be moved in and out through overhead doors with the following exceptions. The lobby pedestrian doors may be used for such items as carry in/ out materials, luggage and 2 wheel dollies. The wheeled items such as dollies, luggage, etc total weight shall not exceed 50 pounds and no more than 28" in width. All other freight and exhibit materials must use the loading docks.
- Passenger elevators and escalators are not to be used for transporting freight from level to level.
- No golf carts, forklifts, or any other motorized vehicles will be permitted in carpeted areas or lobbies without prior written approval from KEC management.
- No food or beverage samples may be distributed by an exposition sponsoring organization or their exhibitors without prior written approval from KEC's exclusive caterer.
- No alcoholic beverages are allowed at the facility except under the provisions of the Lessee's contract in Section 8.
- All food products distributed by exhibitors must be obtained through KEC's official concessionaire/caterer (Centerplate).
- No dog, cat, or other animal will be permitted on KEC property unless it is under leash control of

its owner. Any animal not under such control will be impounded and removed from grounds by the Louisville and Jefferson County Animal Control Office. The Lessee has the right to ban animals in their leased areas except under the provisions of the Americans with Disabilities Act.

- No door shall be chained or blocked in any manner.
- No furniture shall be removed from the VIP suite, and the conference table shall not be moved within the VIP Board Room.
- No motorized vehicles may be parked outside any building, in the horse barn areas, in any fire lane, or any sidewalk, at any loading dock or any other area unless this area is a designated parking space. All vehicles will be towed at owner's expense.
- All motorized vehicles for display inside buildings will have their batteries disconnected and their gas tanks locked and/or taped as soon as places per Kentucky Fire Marshall Regulations.
- No bicycles are to be operated indoors without prior written approval from KEC management. No skates or skateboards are permitted to be used in or on any KEC property.
- No group or individual may sell items on the property without prior written approval of the Lessee and KEC management.
- Pamphlets, flyers, or any such advertising or informational materials cannot be distributed on non-leased property or in parking areas. Such materials can only be distributed from exhibitor booths with consent of the show management.
- No vehicles, freight, or other show materials shall be stored in any facility without prior written approval from KEC management.
- Tipping of KEC employees is strictly prohibited per Section 6 of the Lessee's contract.
- To comply with the Kentucky Standards of Safety in theaters, motion picture theaters, auditoriums and other similar assembly occupancies with an occupant load of 300 or more; and, in the occupancies where there are non-continuous programs, an audible announcement shall be made prior to the start of each programs to notify occupants of the location of the exits to be used in the event of fire or other emergencies.
- No meeting area shall be totally darkened for any presentation. This includes all audio and visual presentations.

Smoking Policy (11-20-2014)

It is requested that this information be included in show brochures, meetings and/or exhibitor manuals.

- The Kentucky Exposition Center indoor facilities are designated as smoke free spaces.
- There is a ban on all tobacco products including, but not limited to snuff, dip, chewing tobacco, electronic cigarettes, and vaping devices indoors.
- Smoking is permitted outdoors but must be done a minimum distance of 10 feet from building entrances.
- This policy applies to all exhibitors, visitors, attendees, contract personnel and Kentucky Exposition Center employees.
- This policy is strictly enforced and violators are subject to removal.

Policies - Kentucky Sales and Use Tax

Commonwealth of Kentucky
Revenue Cabinet
Frankfort, KY 40620

TO: Persons Using Facilities of the Kentucky State Fair Board

DATE: August 1, 1995

SUBJECT: Application of Kentucky Sales and Use Tax

This letter has been prepared to provide information concerning the Kentucky sales and use tax law to assist you in determining your liability for collecting and remitting the tax. The tax is imposed at the rate of six percent upon gross receipts derived from the sale of admissions and tangible personal property. Also, the renting or leasing of tangible personal property for consideration is treated as a sale subject to the tax.

Persons engaged in making sales of admissions to events such as concerts, rodeos, machinery shows, art exhibits, etc. are liable for the tax on such sales. In addition, sales of tangible personal property such as T-shirts, records, buttons, pins, food, etc. at such events are subject to tax. Further, persons engaged in renting or leasing tangible personal property, except motor vehicles used on public highways, for storage, use or other consumption in Kentucky, are retailers who must report and pay the applicable tax from the gross rental or lease receipts.

There are instances where the Kentucky State Fair Board, by signed contract, has agreed to handle admission sales. In these instances, the tax will be collected and remitted by the Board, thereby relieving the person of this responsibility. However, the person would still be liable for the tax on any sales, leases or rentals of tangible personal property.

Persons who will be conducting events at the facilities of the Kentucky State Fair Board should, at least a week in advance of the scheduled event, contact the Kentucky Taxpayer Service Center, 620 South Third Street, Louisville, KY 40202-2446, telephone number (502) 595-4512, or fax number (502) 595-4205 to obtain proper registration and more detailed information.

Department of Compliance and Taxpayer Assistance
Revenue Cabinet